

Dual NPN-PNP complementary Bipolar transistor

General features

$V_{CE(sat)}$	h_{FE}	I_C
0.35V	>100	1A

- High gain
- Low $V_{CE(sat)}$
- Simplified circuit design
- Reduced component count

Applications

- Push-Pull or Totem-Pole configuration
- MOSFET and IGBT gate driving
- Motor, relay and solenoid driving

Description

The STS01DTP06 is a Hybrid dual NPN-PNP complementary power bipolar transistor manufactured by using the latest low voltage planar technology. The STS01DTP06 is housed in dual island SO-8 package with separated terminals for higher assembly flexibility, specifically recommended to be used in Push-Pull or Totem Pole configuration as post IGBTs and MOSFETs driver.

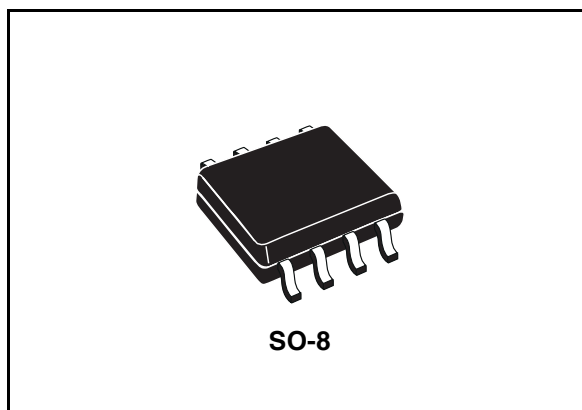

Internal schematic diagram

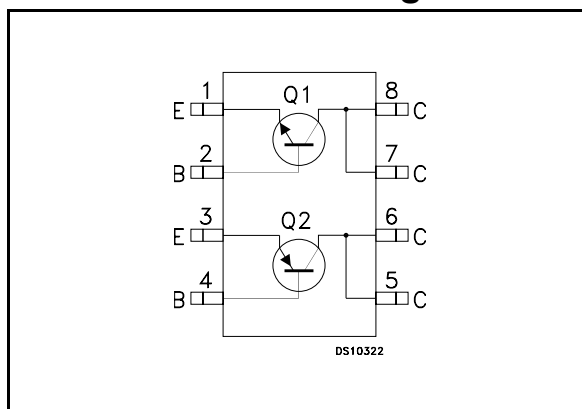

Order codes

Part Number	Marking	Package	Packing
STS01DTP06	S01DTP06	SO-8	Tape & reel

Contents

1	Electrical ratings	3
2	Electrical characteristics	4
2.1	Electrical characteristics (curve)	5
2.2	Test circuits	7
3	Package mechanical data	8
4	Revision history	10

1 Electrical ratings

Table 1. Absolute maximum ratings

Symbol	Parameter	Value		Unit
		NPN	PNP	
V_{CBO}	Collector-base voltage ($I_E = 0$)	60	-60	V
V_{CEO}	Collector-emitter voltage ($I_B = 0$)	30	-30	V
V_{EBO}	Emitter-base voltage ($I_C = 0$)	5	-5	V
I_C	Collector current	3	-3	A
I_{CM}	Collector peak current ($t_P < 5\text{ms}$)	6	-6	A
I_B	Base current	1	-1	A
I_{BM}	Base peak current ($t_P < 1\text{ms}$)	2	-2	A
P_{tot}	Total dissipation at $T_c = 25^\circ\text{C}$ single	2		W
P_{tot}	Total dissipation at $T_c = 25^\circ\text{C}$ couple	1.6		W
T_{stg}	Storage temperature	-65 to 150		$^\circ\text{C}$
T_J	Max. operating junction temperature	150		$^\circ\text{C}$

Table 2. Thermal data

Symbol	Parameter	Value	Unit
$R_{thj-amb}$ ¹	Thermal resistance junction-ambient (Single operation)	Max 62.5	$^\circ\text{C/W}$
$R_{thj-amb}$ ¹	Thermal resistance junction-ambient (Dual operation)	Max 78	$^\circ\text{C/W}$

¹ When mounted on 1 inch square pad of 2 oz. copper, $t \leq 10$ sec.

2 Electrical characteristics

($T_{\text{case}} = 25^{\circ}\text{C}$ unless otherwise specified)

Table 3. Q1-NPN transistor electrical characteristics

Symbol	Parameter	Test Conditions	Min.	Typ.	Max.	Unit
I_{CBO}	Collector cut-off current ($I_{\text{E}} = 0$)	$V_{\text{CB}} = 60\text{V}$			0.1	μA
I_{CEO}	Collector cut-off current ($I_{\text{B}} = 0$)	$V_{\text{CE}} = 30\text{V}$			1	μA
I_{EBO}	Emitter cut-off current ($I_{\text{C}} = 0$)	$V_{\text{EB}} = 5\text{V}$			1	μA
$V_{(\text{BR})\text{CEO}}^{(1)}$	Collector-emitter breakdown voltage ($I_{\text{B}} = 0$)	$I_{\text{C}} = 10\text{mA}$	30			V
$V_{\text{CE}(\text{sat})}^{(1)}$	Collector-emitter saturation voltage	$I_{\text{C}} = 1\text{A}$ $I_{\text{B}} = 10\text{mA}$ $I_{\text{C}} = 2\text{A}$ $I_{\text{B}} = 100\text{mA}$		0.35	1 0.7	V V
$V_{\text{BE}(\text{sat})}^{(1)}$	Base-emitter saturation voltage	$I_{\text{C}} = 1\text{A}$ $I_{\text{B}} = 10\text{mA}$		0.85	1.1	V
$h_{\text{FE}}^{(1)}$	DC current gain	$I_{\text{C}} = 1\text{A}$ $V_{\text{CE}} = 2\text{V}$ $I_{\text{C}} = 3\text{A}$ $V_{\text{CE}} = 2\text{V}$	100 30			

1. Pulsed: Pulse duration = 300 ms, duty cycle $\leq 1.5\%$

($T_{\text{case}} = 25^{\circ}\text{C}$ unless otherwise specified)

Table 4. Q2-PNP transistor electrical characteristics

Symbol	Parameter	Test Conditions	Min.	Typ.	Max.	Unit
I_{CBO}	Collector cut-off current ($I_{\text{E}} = 0$)	$V_{\text{CB}} = -60\text{V}$			-0.1	μA
I_{CEO}	Collector cut-off current ($I_{\text{B}} = 0$)	$V_{\text{CE}} = -30\text{V}$			-1	μA
I_{EBO}	Emitter cut-off current ($I_{\text{C}} = 0$)	$V_{\text{EB}} = -5\text{V}$			-1	μA
$V_{(\text{BR})\text{CEO}}^{(1)}$	Collector-emitter breakdown voltage ($I_{\text{B}} = 0$)	$I_{\text{C}} = -10\text{mA}$	-30			V
$V_{\text{CE}(\text{sat})}^{(1)}$	Collector-emitter saturation voltage	$I_{\text{C}} = -1\text{A}$ $I_{\text{B}} = -10\text{mA}$ $I_{\text{C}} = -2\text{A}$ $I_{\text{B}} = -100\text{mA}$		-0.35	-1 -0.7	V V

Table 4. Q2-PNP transistor electrical characteristics

Symbol	Parameter	Test Conditions		Min.	Typ.	Max.	Unit
$V_{BE(sat)}^{(1)}$	Base-emitter saturation voltage	$I_C = -1A$	$I_B = -10mA$		-0.85	-1.1	V
$h_{FE}^{(1)}$	DC current gain	$I_C = -1A$ $I_C = -3A$	$V_{CE} = -2V$ $V_{CE} = -2V$	100 30			

1. Pulsed: Pulse duration = 300 ms, duty cycle \leq 1.5 %

2.1 Electrical characteristics (curve)

Figure 1. Reverse biased area Q1 NPN transistor **Figure 2. DC current gain Q1 NPN transistor**

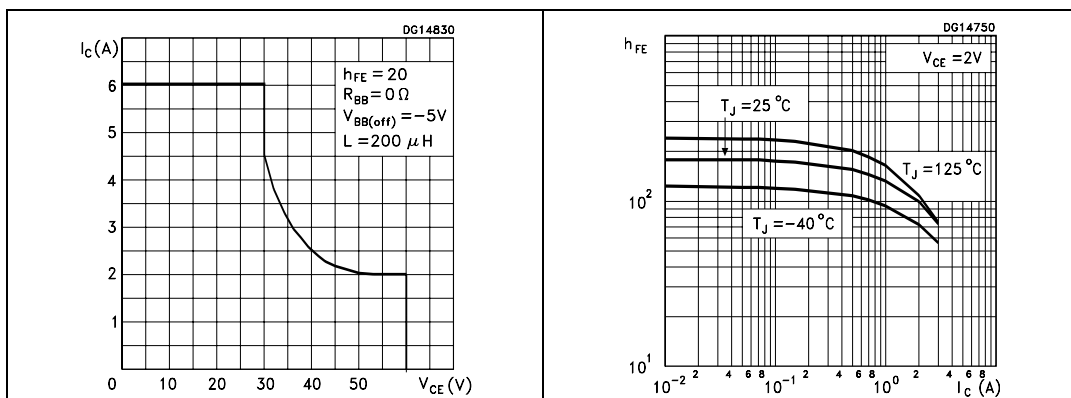

Figure 3. DC current gain Q1 NPN transistor **Figure 4. Collector-emitter saturation voltage Q1 NPN transistor**

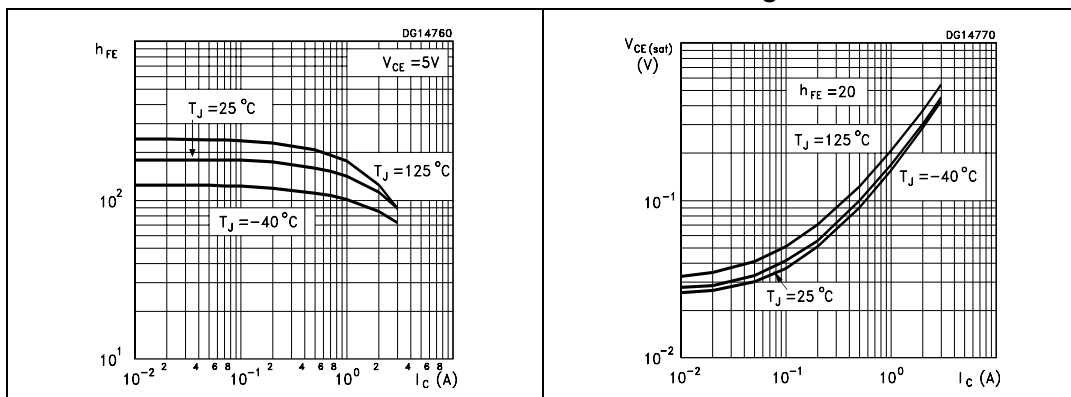

Figure 5. Base-emitter saturation voltage Q1 NPN transistor

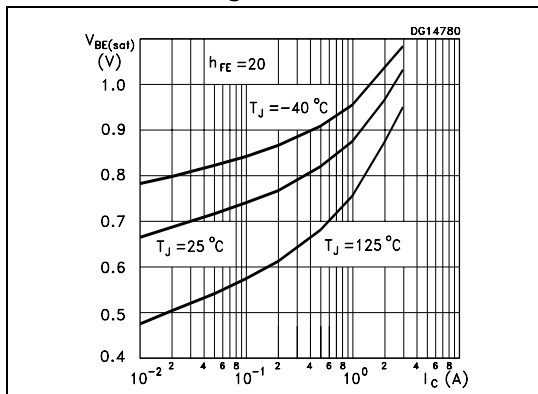

Figure 6. Reverse biased area Q2 PNP transistor

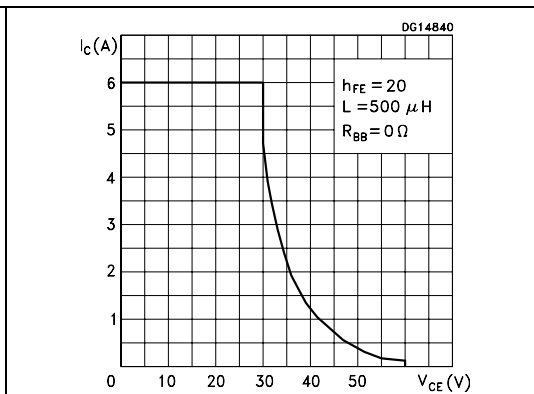

Figure 7. DC current gain Q2 PNP transistor

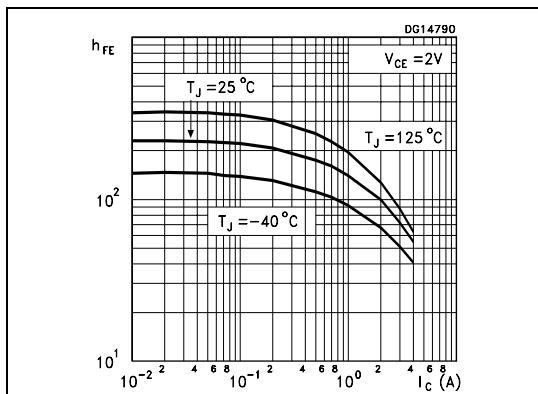

Figure 8. DC current gain Q2 PNP transistor

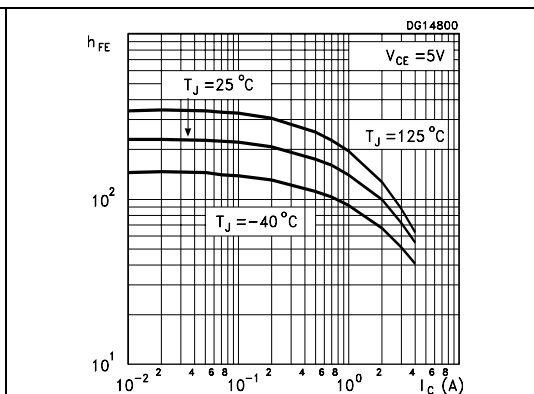

Figure 9. Collector-emitter saturation voltage Q2 PNP transistor

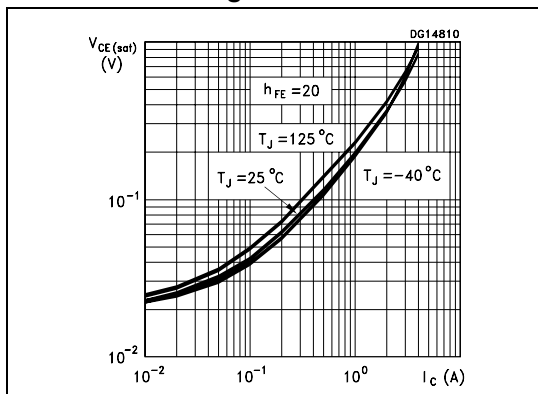
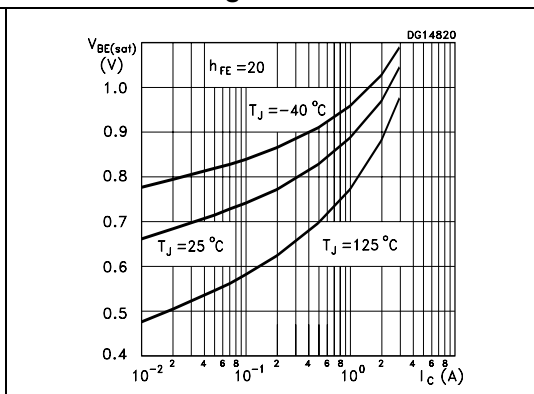
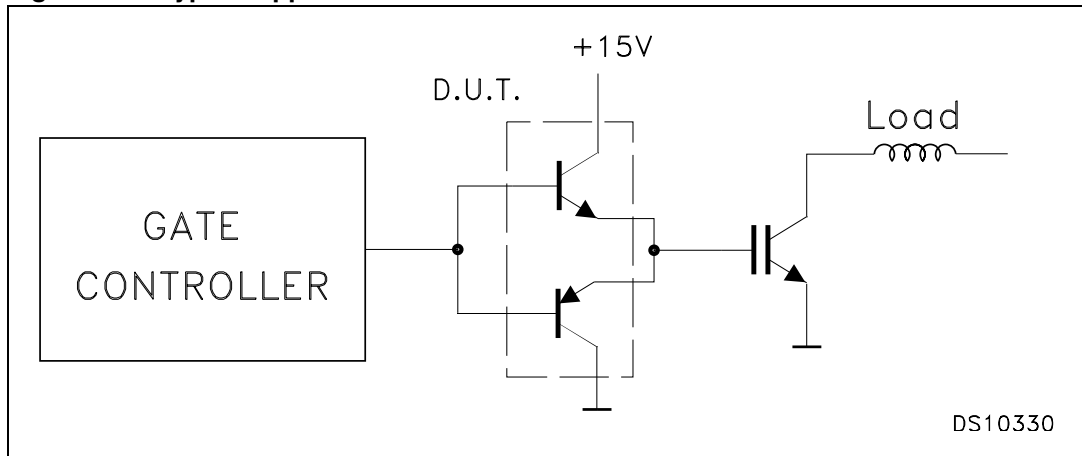

Figure 10. Base-emitter saturation voltage Q2 PNP transistor



2.2 Test circuits

Figure 11. Typical application



3 Package mechanical data

In order to meet environmental requirements, ST offers these devices in ECOPACK® packages. These packages have a Lead-free second level interconnect. The category of second level interconnect is marked on the package and on the inner box label, in compliance with JEDEC Standard JESD97. The maximum ratings related to soldering conditions are also marked on the inner box label. ECOPACK is an ST trademark. ECOPACK specifications are available at: www.st.com

SO-8 MECHANICAL DATA

DIM.	mm.			inch		
	MIN.	TYP.	MAX.	MIN.	TYP.	MAX.
A			1.75			0.068
a1	0.1		0.25	0.003		0.009
a2			1.65			0.064
a3	0.65		0.85	0.025		0.033
b	0.35		0.48	0.013		0.018
b1	0.19		0.25	0.007		0.010
C	0.25		0.5	0.010		0.019
c1	45 (typ.)					
D	4.8		5.0	0.188		0.196
E	5.8		6.2	0.228		0.244
e		1.27			0.050	
e3		3.81			0.150	
F	3.8		4.0	0.14		0.157
L	0.4		1.27	0.015		0.050
M			0.6			0.023
S	8 (max.)					

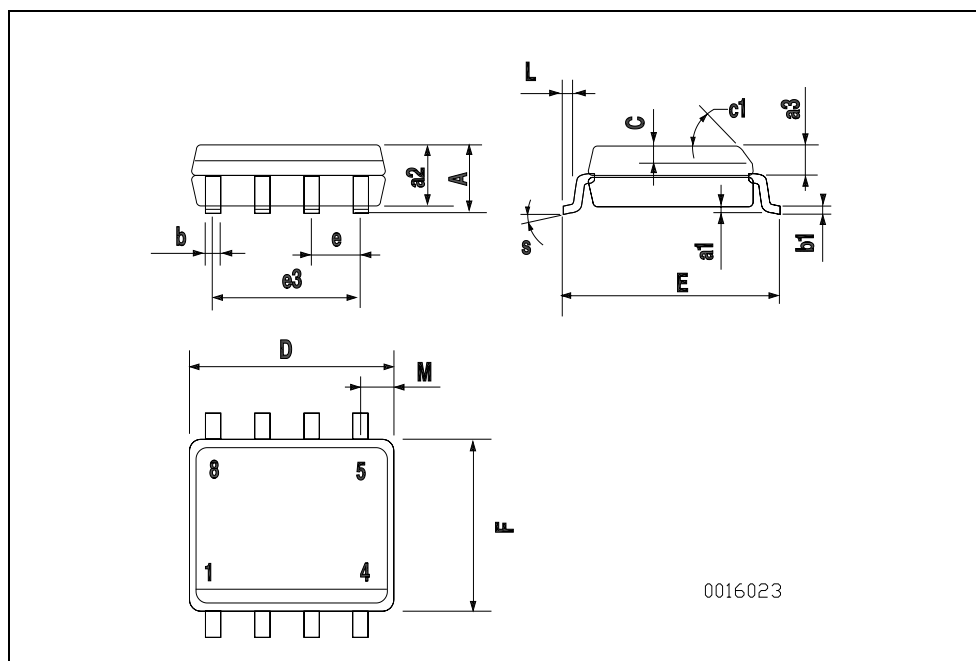

4 Revision history

Table 5. Revision history

Date	Revision	Changes
22-Apr-2005	1	Initial release.
22-Mar-2006	2	New template
30-Mar-2006	3	The limit of current in figure number six has been modified from 6.5A to 6A.

Please Read Carefully:

Information in this document is provided solely in connection with ST products. STMicroelectronics NV and its subsidiaries ("ST") reserve the right to make changes, corrections, modifications or improvements, to this document, and the products and services described herein at any time, without notice.

All ST products are sold pursuant to ST's terms and conditions of sale.

Purchasers are solely responsible for the choice, selection and use of the ST products and services described herein, and ST assumes no liability whatsoever relating to the choice, selection or use of the ST products and services described herein.

No license, express or implied, by estoppel or otherwise, to any intellectual property rights is granted under this document. If any part of this document refers to any third party products or services it shall not be deemed a license grant by ST for the use of such third party products or services, or any intellectual property contained therein or considered as a warranty covering the use in any manner whatsoever of such third party products or services or any intellectual property contained therein.

UNLESS OTHERWISE SET FORTH IN ST'S TERMS AND CONDITIONS OF SALE ST DISCLAIMS ANY EXPRESS OR IMPLIED WARRANTY WITH RESPECT TO THE USE AND/OR SALE OF ST PRODUCTS INCLUDING WITHOUT LIMITATION IMPLIED WARRANTIES OF MERCHANTABILITY, FITNESS FOR A PARTICULAR PURPOSE (AND THEIR EQUIVALENTS UNDER THE LAWS OF ANY JURISDICTION), OR INFRINGEMENT OF ANY PATENT, COPYRIGHT OR OTHER INTELLECTUAL PROPERTY RIGHT.

UNLESS EXPRESSLY APPROVED IN WRITING BY AN AUTHORIZED REPRESENTATIVE OF ST, ST PRODUCTS ARE NOT DESIGNED, AUTHORIZED OR WARRANTED FOR USE IN MILITARY, AIR CRAFT, SPACE, LIFE SAVING, OR LIFE SUSTAINING APPLICATIONS, NOR IN PRODUCTS OR SYSTEMS, WHERE FAILURE OR MALFUNCTION MAY RESULT IN PERSONAL INJURY, DEATH, OR SEVERE PROPERTY OR ENVIRONMENTAL DAMAGE.

Resale of ST products with provisions different from the statements and/or technical features set forth in this document shall immediately void any warranty granted by ST for the ST product or service described herein and shall not create or extend in any manner whatsoever, any liability of ST.

ST and the ST logo are trademarks or registered trademarks of ST in various countries.

Information in this document supersedes and replaces all information previously supplied.

The ST logo is a registered trademark of STMicroelectronics. All other names are the property of their respective owners.

© 2006 STMicroelectronics - All rights reserved

STMicroelectronics group of companies

Australia - Belgium - Brazil - Canada - China - Czech Republic - Finland - France - Germany - Hong Kong - India - Israel - Italy - Japan - Malaysia - Malta - Morocco - Singapore - Spain - Sweden - Switzerland - United Kingdom - United States of America

www.st.com

